

Noncontact Displacement/Vibration

FK series

FK series



Sales SHINKAWA Electric Co., Ltd.

3rd Fl. Shin-kojmachichi Bldg.3-3 Kojimachi 4-chome, Chiyoda-ku, Tokyo 102-0083, Japan
Tel : 81-3-3263-4417 Fax : 81-3-3262-2171 E-mail : st-mkt@shinkawa.co.jp
Web : <http://www.shinkawaelectric.com/en/>

Manufacturing SHINKAWA Sensor Technology, Inc.

4-22 Yoshikawa-kogyodanchi, Higashihiroshima, Hiroshima 739-0153, Japan
Tel : 81-82-429-1118 Fax : 81-82-429-0804 E-mail : info@sst.shinkawa.co.jp
Web : <http://www.sst-shinkawa.co.jp>

- * Specifications, outline drawings and other written information can be changed without notice.
- * When exporting Shinkawa products, permission may be required for export or service transactions, pursuant to the provision of the Foreign Exchange and Foreign Trade Act.
When re-exporting Shinkawa products, permission may be required from the US Department of Commerce, pursuant to the provision of the Export Administration Regulation (EAR).
Please contact our service representative for further information.
- * All company and product names in this brochure are trademarks or registered trademarks.



Published in Nov.2015

Printed in Japan 11406E1.0-15102



Suitable for measurements of shaft vibration, axial position, rotational speed, phase mark, eccentricity and differencial expansion on small high speed rotating machinery to large turbines and compressors



FK series transducer is an eddy current displacement sensor and it can be applied for condition monitoring of critical machines in a plant.

Features

- **Environmental friendly design**
lead-free soldering , RoHS compliance and reduced footprint
- **Flexible mounting options**
DIN-rail adaptor, 4-screw-crimp plate adaptor (to replace VK series and others)
- **Quality sensor with excellent environmental resistance**
sensor without impact of oil droplets and oil mist can be installed in two machines in principle
- **API Standard 670(5th Edition)compliant**
- **Intrinsically safe (TIIS, CSA, ATEX, NEPSI, KTL), and marine certified (NK, LR)**
- **CE compliant**

Example of Application

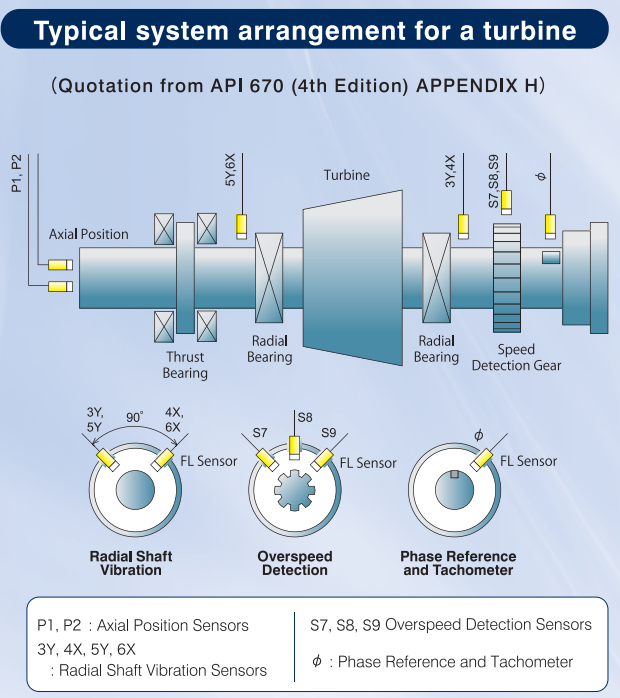
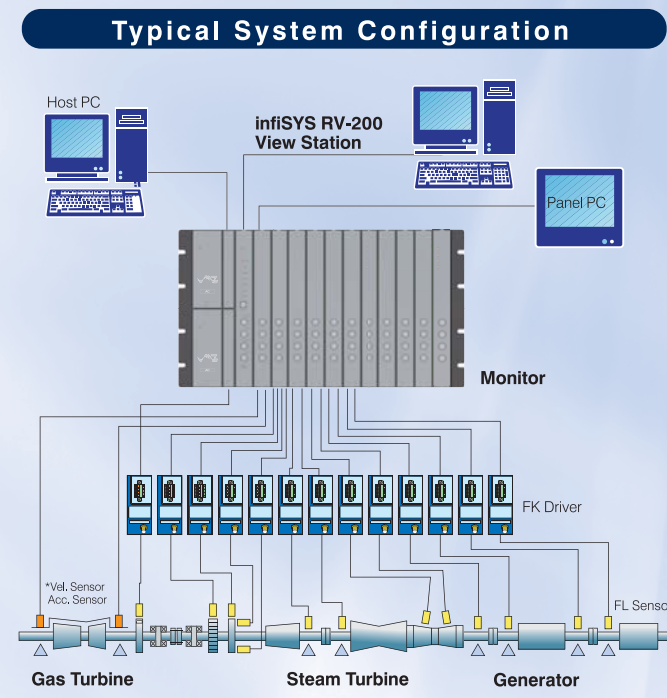

Applications

Condition monitoring of critical machines supported by journal bearings. Such as steam/gas turbines, generators, compressors and so on.



FK System Configuration

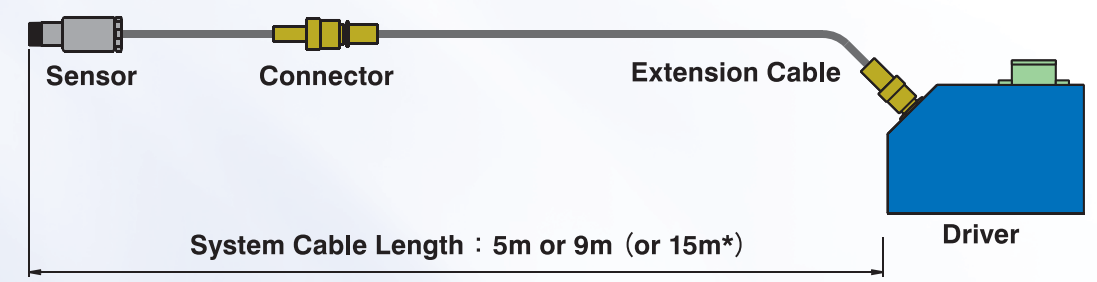

* FK-302F3 only

Specifications

	FK - 202F	FK - 302F	FK - 452F
Calibration Material	JIS SCM440 flat surface		
Measuring Range	0.25mm to 2.25mm from sensor tip	0.25mm to 3.25mm from sensor tip	0.5mm to 5.0mm from sensor tip
Scale Factor	7.87V/mm	5.0V/mm	3.94V/mm
Scale Factor Error ^{*1}	Within ±5% of 7.87V/mm (for 5m system) Within ±6.5% of 7.87V/mm (for 9m system) (including interchangeability errors) Step : 0.25mm, Linear range : 2mm	Within ±4% of 5.0V/mm (if calibrated as a system) Within ±10% of 5.0V/mm (including interchangeability errors) Step : 0.25mm, Linear range : 3mm	Within ±6% of 3.94V/mm (if calibrated as a system) Within ±10% of 3.94V/mm (including interchangeability errors) Step : 0.5mm, Linear range : 4mm
Linearity ^{*1}	Within ±25μm of 7.87V/mm Straight line : (for 5m system) Within ±38μm of 7.87V/mm Straight line : (for 9m system) (including interchangeability errors) Linear range : 2mm	Within ±30μm of 5.0V/mm Straight line: (if calibrated as a system) Within ±45μm of 5.0V/mm Straight line: (including interchangeability errors) Linear range : 3mm	Within ±50μm of 3.94V/mm Straight line: (if calibrated as a system) Within ±100μm of 3.94V/mm Straight line: (including interchangeability errors) Linear range : 4.5mm
Frequency Response ^{*1}	DC to 10kHz(-3dB)	DC to 10kHz or more(-3dB)	DC to 10kHz(-3dB)
Sensor Tip Diameter	Approx. 5mm or 8mm dia.	Approx. 10mm dia.	Approx. 11mm dia.
System Cable Length	5m, 9m, (15m ^{*2})		
Operating Temperature Range	Sensor : -40 to +177°C Extension Cable : -40 to +177°C Driver : -40 to +80°C		
Operating Humidity Range	30 to 95%RH (non-condensing, non-submerged)(Sensor body : 100%RH)		
Power Supply	-24VDC±10%		
Terminal Block	Spring lock terminal		

*1 The above specification apply at 25°C with -24VDC power supply and load resistance 10kΩ and JIS SCM440 target.
*2 FK-302F3 only.

	FK - 602F	FK - 143F	FK - 263F
Calibration Material	JIS SCM440 flat surface		
Measuring Range	0.5mm to 6.5mm from sensor tip	3mm to 16.5mm from sensor tip	3mm to 29mm from sensor tip
Sensitivity ^{*1}	2.5V/mm	0.8V/mm	0.4V/mm
Sensitivity Error ^{*1}	Within ±4%		
Linearity ^{*1}	Within ±70μm of 2.5V/mm Straight line: (if calibrated as a system) Within ±90μm of 2.5V/mm Straight line: (including interchangeability errors) Linear range : 6mm	Within ±200μm of 0.8V/mm Straight line: (if calibrated as a system) Within ±270μm of 0.8V/mm Straight line: (including interchangeability errors) Linear range : 13.5mm	Within ±250μm of 0.4V/mm Straight line: (if calibrated as a system) Within ±400μm of 0.4V/mm Straight line: (including interchangeability errors) Linear range : 26mm
Frequency Response ^{*1}	DC to 10kHz or more(-3dB)	DC to 200Hz or more(-3dB)	
Sensor Tip Diameter	Approx. 18mm dia.	Approx. 27mm dia.	Approx. 50mm dia.
System Cable Length	5m or 9m		
Operating Temperature Range	Sensor : -40 to +125°C Extension Cable : -40 to +125°C Driver : -40 to +80°C		
Operating Humidity Range	30 to 95%RH (non-condensing, non-submerged)(Sensor body : 100%RH)		
Power Supply	-24VDC±10%		
Terminal Block	Spring lock terminal		

*1 The above specification apply at 25°C with -24VDC power supply and load resistance 10kΩ and JIS SCM440 target.

FK Driver Model Code Number and Outline Drawing

Model Code Number **FK-□□□F□-□**

Linear Range	System Cable Length	Mounting Plate
202	2mm	1
302	3mm	2
452	4.5mm	3
602	6mm	4
143	13.5mm	
263	26mm	

Mounting Plate	Mounting Plate
1	DIN rail (35mm) mount
2	Screw mount (50.8 × 50.8mm)
3	Screw mount (92 × 31mm : for VK replacement)
4	Screw mount multi-pitch (50.8 × 50.8mm and 92 × 31mm)

*1 FK 302F only.

FK-□□□F□-1 (DIN rail mount)

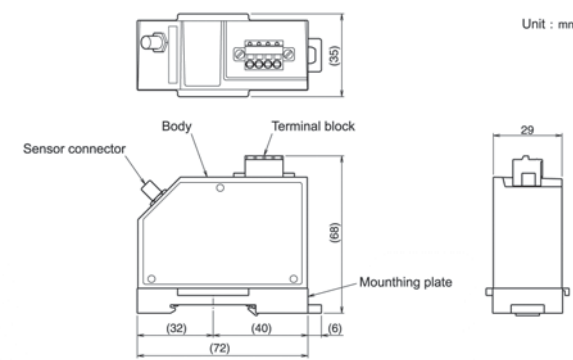

FK-□□□F□-3 (Screw mount : for VK replacement)

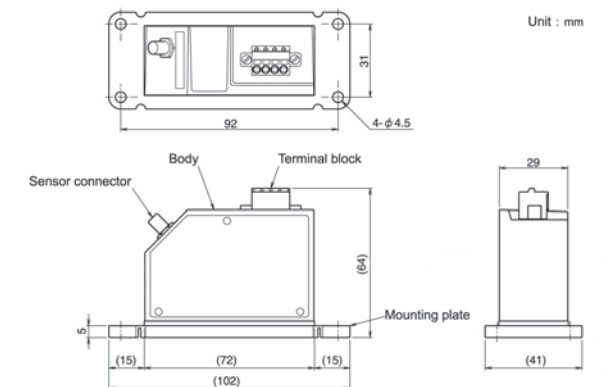

FW Extension Cable Model Code Number and Outline Drawing

Model Code Number **FW-□□□F□-□**

Linear Range	Armor	Cable Length
202	2mm	L
302	3mm	Without armor
452	4.5mm	With armor
602	6mm	(Without fluoro resin coating)
143	13.5mm	80
263	26mm	85

FW-□□□FL (Without armor)

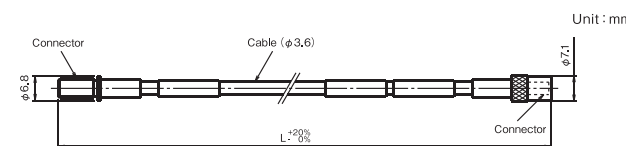

FW-□□□FT (With armor (With fluoro resin coating))

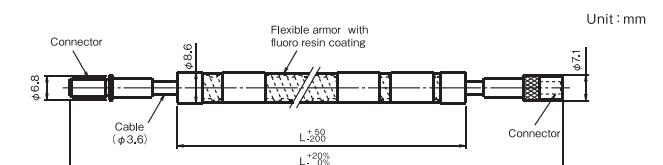

FL-202F (Linear Range : 2mm)

Model Code Number

FL-202F05 - [] - [] - [] - []

Armor	Thread Size	Unthreaded Length	Case Length	Cable Length
L Without armor	M1 M8 × 1	10mm STEP, 0-230mm L1 ≤ L2 - 20mm e.g.) 06=60mm	10mm STEP, 20-250mm e.g.) 25=250mm	05 0.5m 10 1.0m 50 5.0m
A With armor (Without fluoro resin coating)	U1 1/4-28UNF	0.1in. STEP, 0-9.2in. L1 ≤ L2 - 0.7in. e.g.) 04=0.4in.	0.1in. STEP, 0.8-9.9in. e.g.) 35=3.5in.	90 9.0m
T With armor (With fluoro resin coating)				

Specified in mm for M threaded sensor.
Specified in inch for UNF threaded sensor.

Model Code Number

FL-202F08R - [] - [] - [] - []

Thread Size	Unthreaded Length	Case Length	Cable Length
M2 M10 × 1	R5=5mm	03=30mm	05 0.5m 10 1.0m 50 5.0m 90 9.0m
U2 3/8-24UNF	02=0.2in.	12=1.2in.	

Specified in mm for M threaded sensor.
Specified in inch for UNF threaded sensor.

FL-202F05L (Without armor)

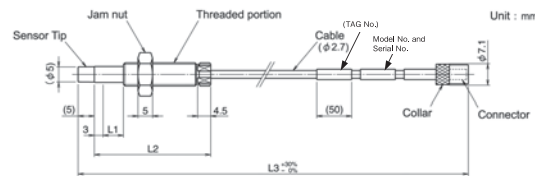

FL-202F05A (With armor (Without fluoro resin coating))

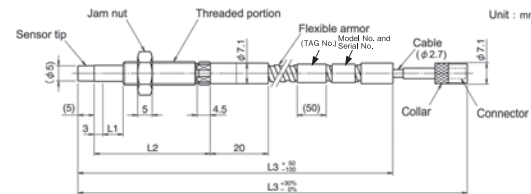

FL-202F05T (With armor (With fluoro resin coating))

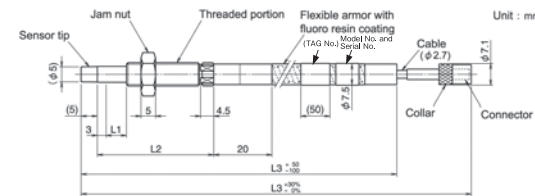

FL-202F08R (Reverse mount type)

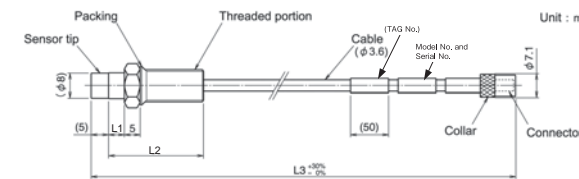

Model Code Number

FL-202F08 - [] - [] - [] - []

Armor	Thread Size	Unthreaded Length	Case Length	Cable Length
L Without armor	M2 M10 × 1	10mm STEP, 0-230mm L1 ≤ L2 - 20mm e.g.) 06=60mm	10mm STEP, 20-250mm e.g.) 25=250mm	05 0.5m 10 1.0m 50 5.0m
A With armor (Without fluoro resin coating)	U2 3/8-24UNF	0.1in. STEP, 0-9.2in. L1 ≤ L2 - 0.7in. e.g.) 04=0.4in.	0.1in. STEP, 0.8-9.9in. e.g.) 35=3.5in.	90 9.0m
T With armor (With fluoro resin coating)				

Specified in mm for M threaded sensor.
Specified in inch for UNF threaded sensor.

FL-302F (Linear Range : 3mm)

Model Code Number

FL-302F10 - [] - [] - [] - []

Armor	Thread Size	Unthreaded Length	Case Length	Cable Length
L Without armor	M1 M12 × 1.25	10mm STEP, 0-100mm L1 ≤ L2 - 20mm e.g.) 02=20mm	10mm STEP, 20-120mm e.g.) 10=100mm	05 0.5m 10 1.0m 50 5.0m 90 9.0m
A With armor (Without fluoro resin coating)	U1 1/2-20UNF	0.1in. STEP, 0-4.0in. L1 ≤ L2 - 0.7in. e.g.) 04=0.4in.	0.1in. STEP, 0.8-4.7in. e.g.) 35=3.5in.	
T With armor (With fluoro resin coating)				

Specified in mm for M threaded sensor.
Specified in inch for UNF threaded sensor.

Model Code Number (Reverse mount type)

FL-302F10R - [] - [] - [] - []

Thread Size	Unthreaded Length	Case Length	Cable Length
M1 M12 × 1.25	R2=2mm	03=25mm	05 0.5m 10 1.0m 50 5.0m 90 9.0m
U1 1/2-20UNF	01=0.1in.	10=1.0in.	

Specified in mm for M threaded sensor.
Specified in inch for UNF threaded sensor.

FL-202F08L (Without armor)

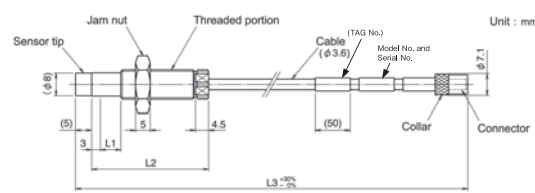

FL-202F08A (With armor (Without fluoro resin coating))

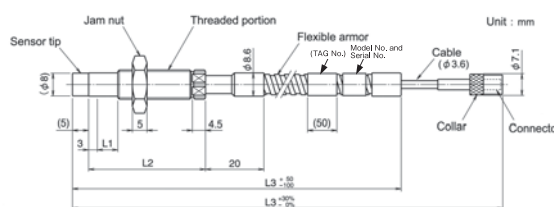

FL-302F10L (Without armor)

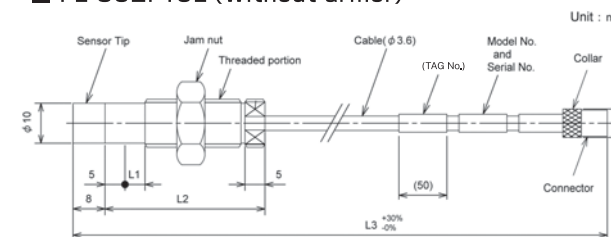

FL-302F10R (Reverse mount type)

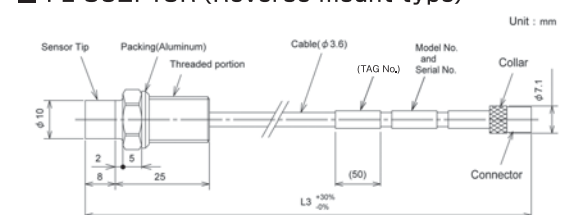

FL-202F08T (With armor (With fluoro resin coating))

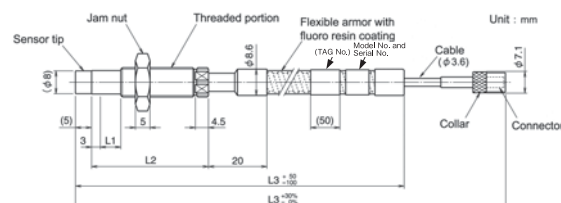

FL-302F10A (With armor (Without fluoro resin coating))

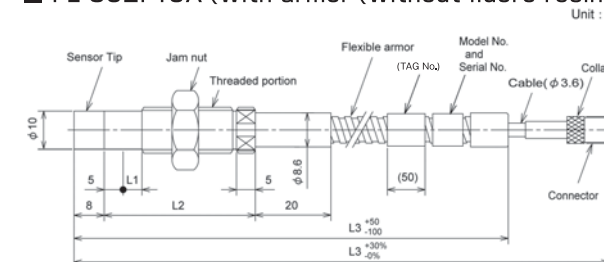

FL-302F10T (With armor (With fluoro resin coating))

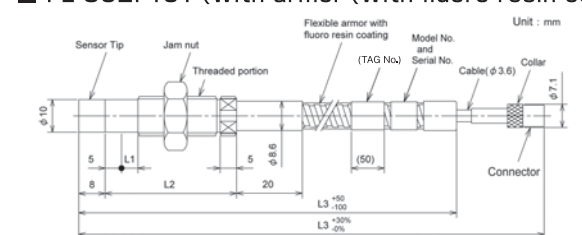

FK-452F

■ Model Code Number

FL-452F11-□-□-□-□-□

Armor	Thread Size	Unthreaded Length	Case Length	Cable Length
L Without armor	M1 M14 × 1.5	10 mm STEP, 0-100 mm L1 ≤ L2 - 20 mm e.g.) 02 = 20 mm	10 mm STEP, 20 - 120 mm e.g.) 10 = 100 mm	05 0.5 m 10 1.0 m 50 5.0 m 90 9.0 m
A With armor (Without fluoro resin coating)	U1 1/2 - 20UNF	0.1 in. STEP, 0 - 4.0 in. L1 ≤ L2 - 0.7 in. e.g.) 04 = 0.4 in.	0.1 in. STEP, 0.8 - 4.7 in. e.g.) 35 = 3.5 in.	
T With armor (With fluoro resin coating)				

Specified in mm for M threaded sensor.
Specified in inch for UNF threaded sensor.

■ FL-452F11L (Without armor)

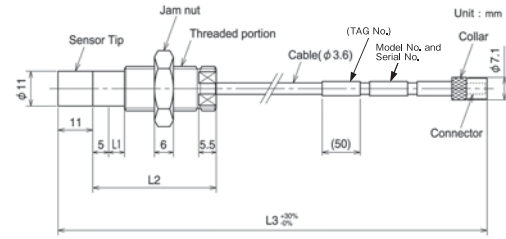

■ FL-452F11A (With armor (Without fluoro resin coating))

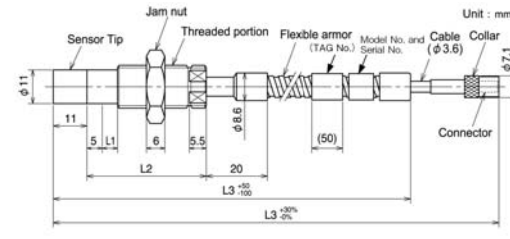

■ FL-452F11T (With armor (With fluoro resin coating))

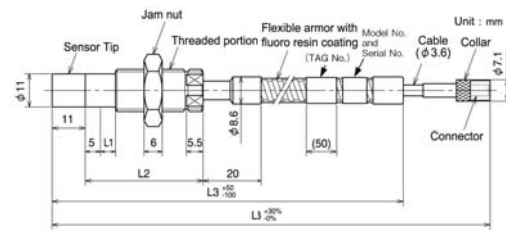

FL-602F

■ Model Code Number

FL-602F18-□-□-□-□-□

Armor	Thread Size	Unthreaded Length	Case Length	Cable Length
L Without armor	M1 M20 × 1.5	10 mm STEP, 0-80 mm L1 ≤ L2 - 40 mm e.g.) 02=20 mm	10 mm STEP, 40-120 mm e.g.) 10=100 mm	05 0.5 m 10 1.0 m 50 5.0 m 90 9.0 m
A With armor (Without fluoro resin coating)	U1 7/8-14UNF	0.1 in. STEP, 0-3.1 in. L1 ≤ L2 - 1.6 in. e.g.) 04=0.4 in.	0.1 in. STEP, 1.6-4.7 in. e.g.) 35=3.5 in.	
T With armor (With fluoro resin coating)				

Specified in mm for M threaded sensor.
Specified in inch for UNF threaded sensor.

■ FL-602F18L (Without armor)

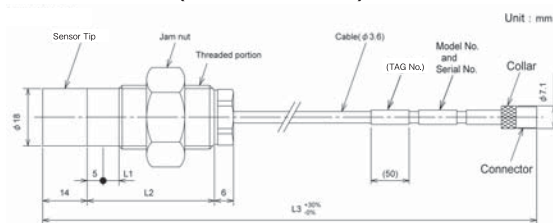

■ FL-602F18A (With armor (Without fluoro resin coating))

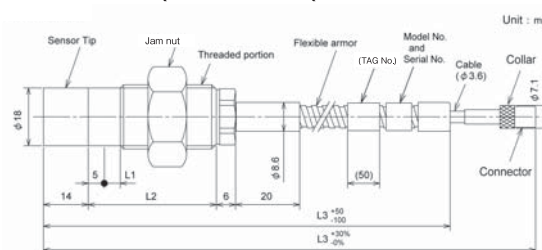

■ FL-602F18T (With armor (With fluoro resin coating))

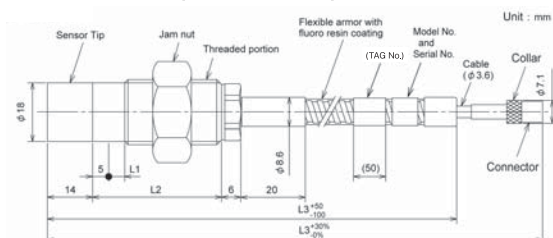

FL-143F

■ Model Code Number

FL-143F27-□-□-□-□-□

Armor	Thread Size	Unthreaded Length	Case Length	Cable Length
L Without armor	M1 M30 × 1.5	10 mm STEP 0-60 mm L1 ≤ L2 - 40 mm e.g.) 02 = 20 mm	10 mm STEP, 40-100 mm e.g.) 10 = 100 mm	05 0.5 m 10 1.0 m 50 5.0 m 90 9.0 m
A With armor (Without fluoro resin coating)	U1 1 1/4-12UNF	0.1 in. STEP, 0-2.4 in. L1 ≤ L2 - 1.5 in. e.g.) 04 = 0.4 in.	0.1 in. STEP, 1.6-3.9 in. e.g.) 35 = 3.5 in.	
T With armor (With fluoro resin coating)				

Specified in mm for M threaded sensor.
Specified in inch for UNF threaded sensor.

■ FL-143F27L (Without armor)

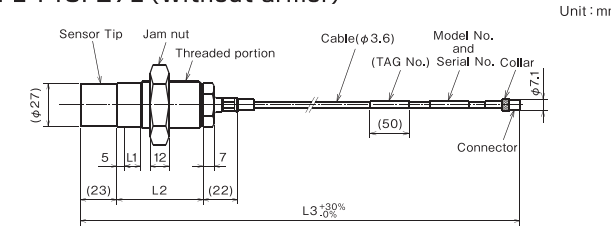

■ FL-143F27A (With armor (Without fluoro resin coating))

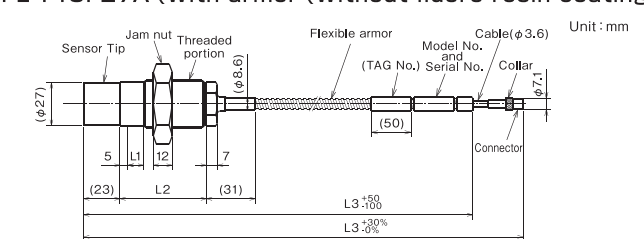

■ FL-143F27T (With armor (With fluoro resin coating))

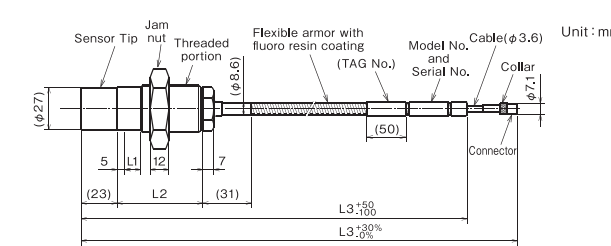

■ Model Code Number (Lateral cable connection type)

FL-143F28-□-M1-00-00-□

Armor	Thread Size	Cable Length
L Without armor	M1 4-M6 DEPTH 14	05 0.5 m 10 1.0 m 50 5.0 m 90 9.0 m
A With armor (Without fluoro resin coating)		
T With armor (With fluoro resin coating)		

■ FL-143F28L (Without armor)

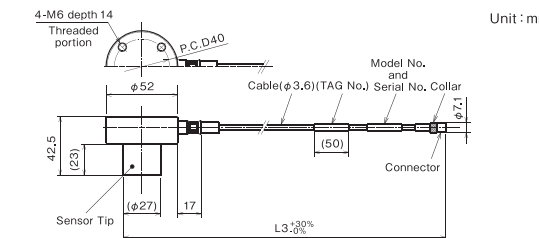

■ FL-143F28A (With armor (Without fluoro resin coating))

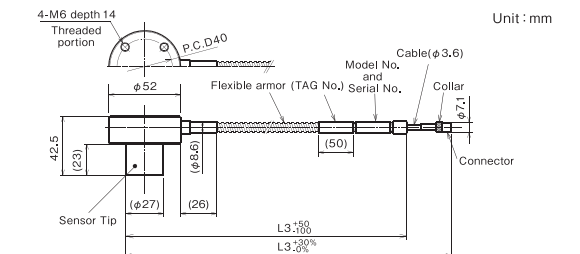

■ FL-143F28T (With armor (With fluoro resin coating))

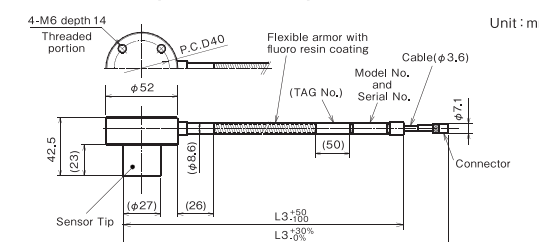

FL-263F

Model Code Number

FL-263F50 - - **00** - -

Armor	Thread Size	Case Length	Cable Length
L Without armor	M1 M24 × 1.5	10 mm STEP, 40-100 mm e.g.) 10 = 100 mm	05 0.5 m
A With armor (Without fluoro resin coating)	U1 1-12UNF	0.1 in. STEP, 1.6-3.9 in. e.g.) 35 = 3.5 in.	10 1.0 m 50 5.0 m 90 9.0 m
T With armor (With fluoro resin coating)		Specified in mm for M threaded sensor. Specified in inch for UNF threaded sensor.	

FL-263F50L (Without armor)

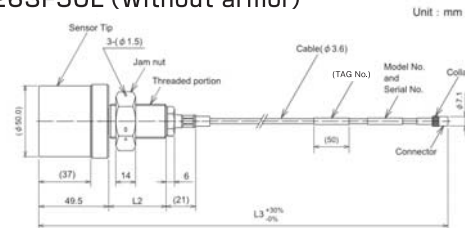

FL-263F50A (With armor (Without fluoro resin coating))

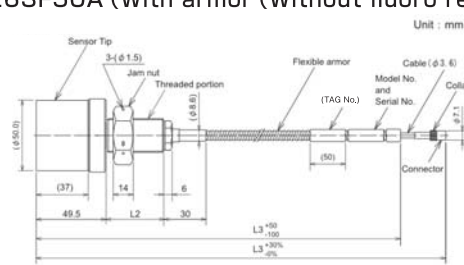

FL-263F50T (With armor (With fluoro resin coating))

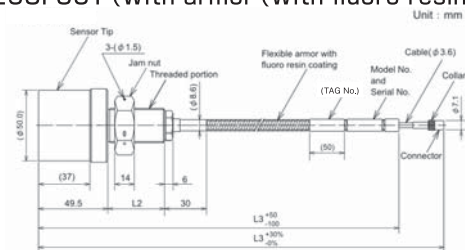

Model Code Number (Lateral cable connection type)

FL-263F55 - **M1-00-00** -

Armor	Cable Length
L Without	05 0.5 m
A With armor (Without fluoro resin coating)	10 1.0 m 50 5.0 m 90 9.0 m
T With armor (With fluoro resin coating)	

FL-263F55L (Without armor)

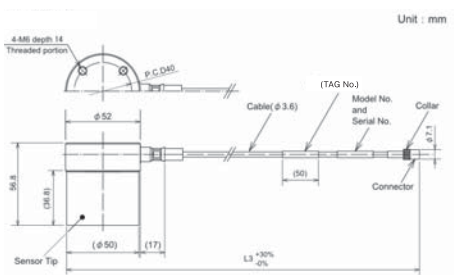

FL-263F55A (With armor (Without fluoro resin coating))

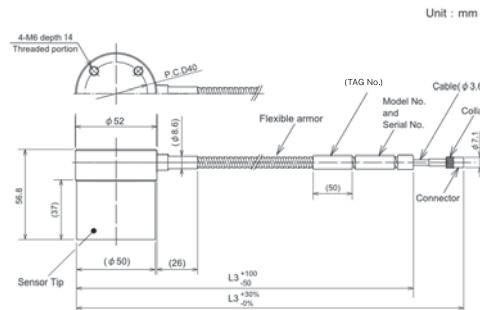

FL-263F55T (With armor (With fluoro resin coating))

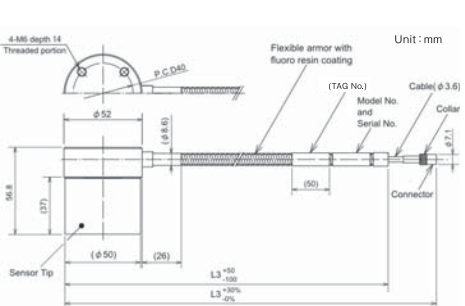

Characteristics Data (Target Material : SCM440 Flat Face Target Size: Triple Diameter or more of Sensor Tip)

FK-202F

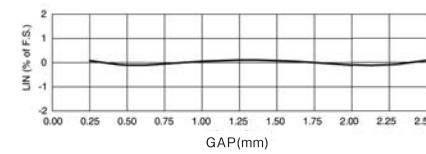
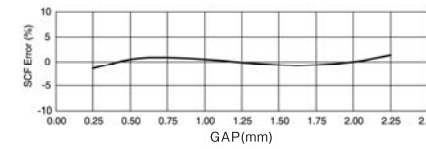
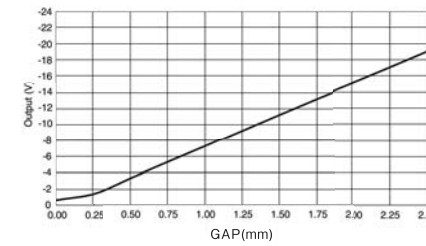

FK-302F

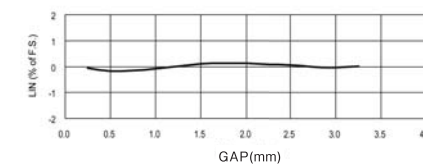
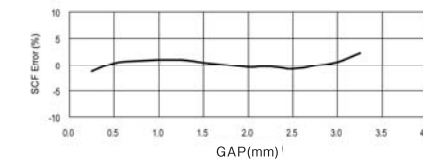
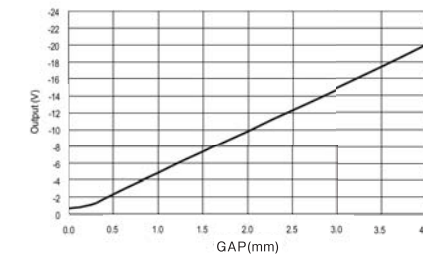

FK-452F

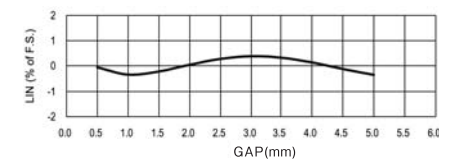
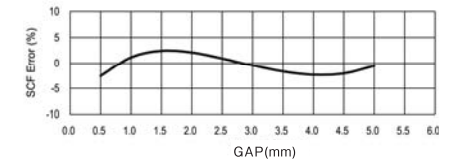
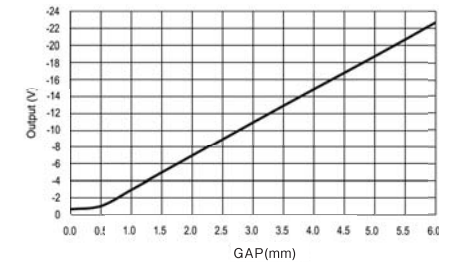

FK-602F

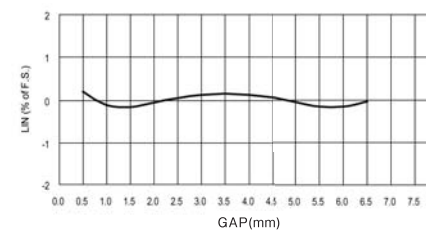
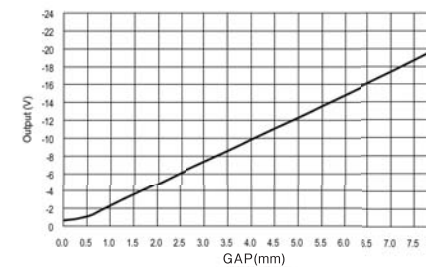

FK-143F

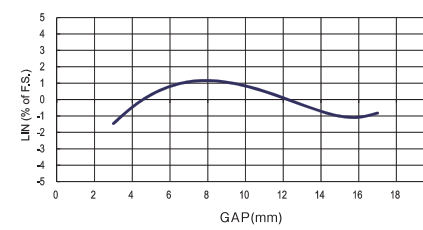
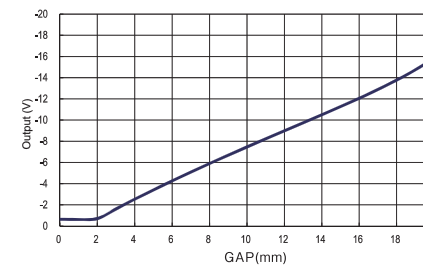

FK-263F

